

EMC TEST REPORT
For
GUANGZHOU HUICHI INDUSTRIAL DEVELOPMENT CO.,LTD
Switchable Smart Film

Model No. : CT2, GT, GT2, GT10, GT16, CT1, CT10, CT16,HS, QH, SH

Prepared for : GUANGZHOU HUICHI INDUSTRIAL DEVELOPMENT
CO.,LTD

Address : 1/4 LONGTENG INDUSTRIAL YUANXIA VILLAGE
LONGGUI BAIYUN DISTRICT GUANGZHOU

Prepared by : SHENZHEN RONGBIAO TESTING SERVICES CO., LTD

Address : LIANTAN INDUSTRIAL No.95 OF LUOHU SHENZHEN
CHINA.

Report Number : RBT210615203ER-1

Date of Test : 2021-06-11 to 2021-06-17

Date of Report : 2021-06-17

TABLE OF CONTENT

Test Report Description	Page
1. SUMMARY OF TEST RESULT.....	6
2. GENERAL INFORMATION.....	7
2.1. Description of Device (EUT).....	7
2.2. Description of Test Facility.....	7
2.3. Measurement Uncertainty.....	7
3. MEASURING DEVICE AND TEST EQUIPMENT.....	7
3.1. For Power Line Conducted Emission Measurement.....	7
3.2. For Magnetic Emission Measurement.....	7
3.3. For Radiated Emission Measurement.....	7
3.4. For Harmonic Current/Flicker Measurement.....	7
3.5. For Electrostatic Discharge Immunity Test.....	7
3.6. For RF Strength Susceptibility Test.....	7
3.7. For Electrical Fast Transient/Burst Immunity Test.....	7
3.8. For Surge Immunity Test.....	7
3.9. For Injected Current Susceptibility Test.....	7
3.10. For Magnetic Field Immunity Test.....	7
3.11. For Voltage Dips and Interruptions Immunity Test.....	7
4. POWER LINE CONDUCTED EMISSION MEASUREMENT.....	8
4.1. Block Diagram of Test Setup.....	8
4.2. Measuring Standard and Limits.....	8
4.3. Operating Condition of EUT.....	8
4.4. Test Procedure.....	9
4.5. Measuring Results.....	9
5. MAGNETIC FIELD EMISSION MEASUREMENT.....	12
5.1. Block Diagram of Test Setup.....	12
5.2. Measuring Standard and Limits.....	12
5.3. Operating Condition of EUT.....	12
5.4. Test Procedure.....	13
5.5. Measuring Results.....	13
6. RADIATED EMISSION MEASUREMENT.....	17
6.1. Block Diagram of Test Setup.....	17
6.2. Measuring Standard and Limits.....	17
6.3. Operating Condition of EUT.....	18
6.4. Test Procedure.....	18
6.5. Measuring Results.....	18
7. HARMONIC CURRENT EMISSION MEASUREMENT.....	21
7.1. Block Diagram of Test Setup.....	21
7.2. Measuring Standard.....	21
7.3. Operation Condition of EUT.....	21
7.4. Measuring Results.....	21
8. VOLTAGE FLUCTUATION AND FLICKER MEASUREMENT.....	22
8.1. Block Diagram of Test Setup.....	22
8.2. Measuring Standard.....	22
8.3. Operation Condition of EUT.....	22
8.4. Measuring Results.....	22
9. ELECTROSTATIC DISCHARGE IMMUNITY TEST.....	24
9.1. Block Diagram of Test Setup.....	24

9.2. Test Standard	24
9.3. Severity Levels and Performance Criterion.....	24
9.4. Operating Condition of EUT	25
9.5. Test Procedure	25
9.6. Test Results.....	25
10. RF FIELD STRENGTH SUSCEPTIBILITY TEST	27
10.1. Block Diagram of Test Setup	27
10.2. Test Standard	27
10.3. Severity Levels and Performance Criterion.....	28
10.4. Operating Condition of EUT	28
10.5. Test Procedure	28
10.6. Test Results.....	28
11. ELECTRICAL FAST TRANSIENT/BURST IMMUNITY TEST	30
11.1. Block Diagram of Test Setup	30
11.2. Test Standard	30
11.3. Severity Levels and Performance Criterion.....	30
11.4. Operating Condition of EUT	31
11.5. Test Procedure	31
11.6. Test Results.....	31
12. SURGE IMMUNITY TEST	33
12.1. Block Diagram of Test Setup	33
12.2. Test Standard	33
12.3. Severity Levels and Performance Criterion.....	33
12.4. Operating Condition of EUT	34
12.5. Test Procedure	34
12.6. Test Results.....	34
13. INJECTED CURRENTS SUSCEPTIBILITY TEST.....	36
13.1. Block Diagram of Test Setup	36
13.2. Test Standard	36
13.3. Severity Levels and Performance Criterion.....	36
13.4. Operating Condition of EUT	37
13.5. Test Procedure	37
13.6. Test Results.....	37
14. MAGNETIC FIELD SUSCEPTIBILITY TEST.....	39
14.1. Block Diagram of Test Setup	39
14.2. Test Standard	39
14.3. Severity Levels and Performance Criterion.....	39
14.4. Operating Condition of EUT	40
14.5. Test Procedure	40
14.6. Test Results.....	40
15. VOLTAGE DIPS AND INTERRUPTIONS TEST.....	42
15.1. Block Diagram of Test Setup	42
15.2. Test Standard	42
15.3. Severity Levels and Performance Criterion.....	42
15.4. Operating Condition of EUT	42
15.5. Test Procedure	43
15.6. Test Results.....	43

APPENDIX (Photos of EUT)

TEST REPORT DESCRIPTION

Applicant : GUANGZHOU HUICHI INDUSTRIAL DEVELOPMENT CO.,LTD
Manufacturer : GUANGZHOU HUICHI INDUSTRIAL DEVELOPMENT CO.,LTD
Trade Mark : --
EUT : Switchable Smart Film
Model No. : CT2, GT, GT2, GT10, GT16, CT1, CT10, CT16,HS, QH, SH

Measurement Procedure Used:

EN 55015:2019+A11:2020
EN 61547:2009
EN 61000-3-2:2019
EN 61000-3-3:2013+A1:2019

The device described above is tested by SHENZHEN RONGBIAO TESTING SERVICES CO., LTD to determine the maximum emission levels emanating from the device and the severe levels of the device can endure and its performance criterion. The measurement results are contained in this test report and SHENZHEN RONGBIAO TESTING SERVICES CO., LTD is assumed full responsibility for the accuracy and completeness of these measurements. Also, this report shows that the EUT to be technically compliant with the EN 55015, EN 61547 EN 61000-3-2 and EN 61000-3-3 requirements.

This report applies to above tested sample only and shall not be reproduced in part without written approval of SHENZHEN RONGBIAO TESTING SERVICES CO., LTD

Date of Test : 2021-06-11 to 2021-06-17

Prepared by : 
Tommy Ma /Editor

Reviewer : 
Apple Li /Supervisor

Approved & Authorized Signer : 
Amy Zhang /Manager

Modified History

Rev.	Summary	Date of Rev.	Report No.
V1.0	Original Report	2021-06-17	RBT210615203ER-1

1. SUMMARY OF TEST RESULT

EMISSION			
Description of Test Item	Standard	Limits	Results
Conducted Disturbance at Mains Terminals	EN 55015	Table 2a	Pass
Magnetic Emission	EN 55015	Table 3	Pass
Radiated Disturbance	EN 55015	Table 4	Pass
Harmonic Current Emissions	EN 61000-3-2	Class C	N/A
Voltage Fluctuation and Flicker	EN 61000-3-3	Section 5	Pass
IMMUNITY			
Description of Test Item	Basic Standard	Performance Criteria	Results
Electrostatic Discharge (ESD)	IEC 61000-4-2	B	Pass
Radio-Frequency, Continuous Radiated Disturbance	IEC 61000-4-3	A	Pass
EFT/B Immunity	IEC 61000-4-4	B	Pass
Surge Immunity	IEC 61000-4-5	B	Pass
Conducted RF Immunity	IEC 61000-4-6	A	Pass
Power Frequency Magnetic Field	IEC 61000-4-8	A	Pass
Voltage Dips and Interruptions, 100% Reduction	IEC 61000-4-11	B	Pass
Voltage Dips and Interruptions, 30% Reduction		C	Pass
Note: N/A is an abbreviation for Not Applicable.			

2. GENERAL INFORMATION

2.1. Description of Device (EUT)

EUT : Switchable Smart Film

Model Number : CT2

Applicant : GUANGZHOU HUICHI INDUSTRIAL DEVELOPMENT CO.,LTD

Address : 1/4 LONGTENG INDUSTRIAL YUANXIA VILLAGE LONGGUI BAIYUN
DISTRICT GUANGZHOU

Manufacturer : GUANGZHOU HUICHI INDUSTRIAL DEVELOPMENT CO.,LTD

Address : 1/4 LONGTENG INDUSTRIAL YUANXIA VILLAGE LONGGUI BAIYUN
DISTRICT GUANGZHOU

Date of Received : 2021-06-11

Date of Test : 2021-06-11 to 2021-06-17

3. POWER LINE CONDUCTED EMISSION MEASUREMENT

3.1. Block Diagram of Test Setup

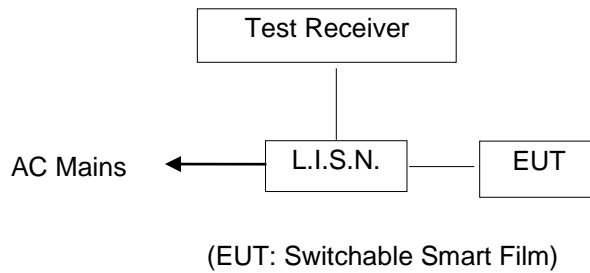

3.2. Measuring Standard and Limits

3.2.1. Standard: EN 55015

3.2.2. Limits

Frequency	At mains terminals (dB μ V)	
	Quasi-peak Level	Average Level
9kHz ~ 50kHz	110	--
50kHz ~ 150kHz	90 ~ 80*	--
150kHz ~ 0.5MHz	66 ~ 56*	56 ~ 46*
0.5MHz ~ 2.51MHz	56	46
2.51MHz ~ 3.0MHz	73	63
3.0MHz ~ 5.0MHz	56	46
5.0MHz ~ 30MHz	60	50

1. At the transition frequency the lower limit applies.
2. * Decreasing linearly with logarithm of the frequency.

3.3. Operating Condition of EUT

3.3.1. Setup the EUT as shown on Section 4.1.

3.3.2. Turn on the power of all equipment.

3.3.3. Let the EUT work in measuring mode (ON) and measure it.

3.4. Test Procedure

The EUT is put on the table, which is 0.8 meter high above the ground and connected to the AC mains through a Line Impedance Stabilization Network (L.I.S.N.). This provided a 50ohm coupling impedance for the tested equipments. Both sides of AC line are checked to find out the maximum conducted emission according to the EN 55015 regulations during conducted emission measurement. And the voltage probe had been used for the load terminals measurement according to the EN 55015 standard.

The bandwidth of the test receiver (R&S ESCS30) is set at 200Hz in 9k~150kHz range and 9kHz in 150k~30MHz range.

The frequency range from 9kHz to 30MHz is checked.

All the test results are listed in Section 4.5. The scanning waveform is put in the following pages.

3.5. Measuring Results

PASS.

The frequency range from 9kHz to 30MHz is investigated.

Please refer to the following pages.

120.0 dBuV/m

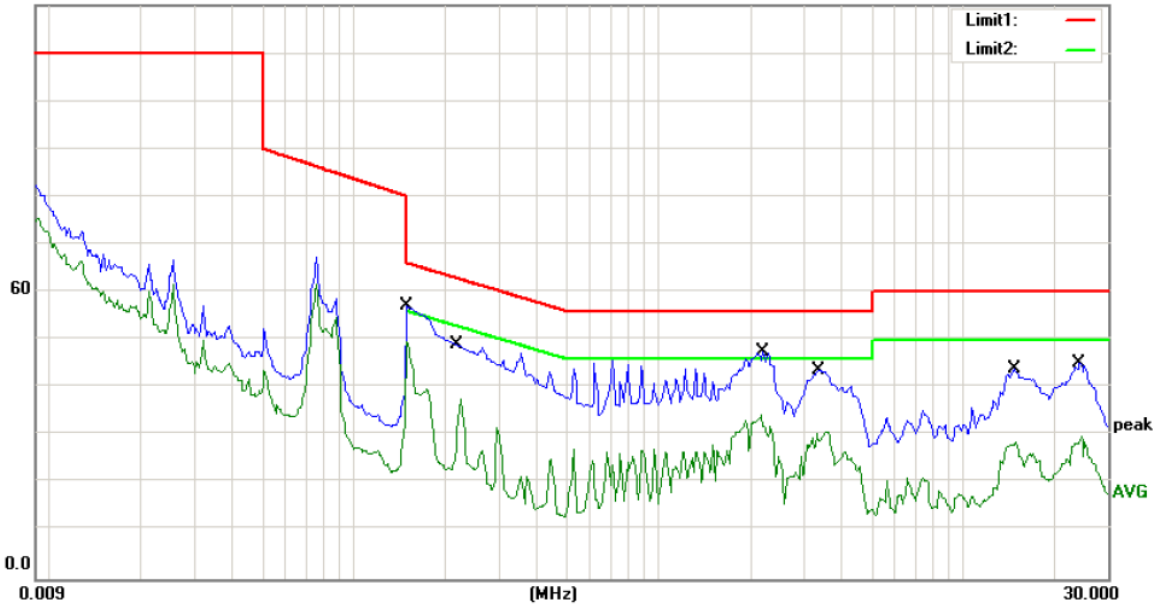

Site Conduction #2 Phase: **L1** Temperature: 26
 Limit: (CE)EN55015_QP Power: AC 230V/50Hz Humidity: 60 %
 Mode: ON
 Note:

No.	Mk.	Freq.	Reading Level	Correct Factor	Measurement	Limit	Over	Detector	Comment
		MHz	dBuV/m	dB	dBuV/m	dBuV/m	dB		
1		0.1500	57.02	0.00	57.02	66.00	-8.98	QP	
2	*	0.1500	49.53	0.00	49.53	56.00	-6.47	AVG	
3		0.2200	48.84	0.00	48.84	62.82	-13.98	QP	
4		0.2200	37.59	0.00	37.59	52.82	-15.23	AVG	
5		2.2100	47.65	0.00	47.65	56.00	-8.35	QP	
6		2.2100	34.49	0.00	34.49	46.00	-11.51	AVG	
7		3.3600	43.79	0.00	43.79	56.00	-12.21	QP	
8		3.3600	30.71	0.00	30.71	46.00	-15.29	AVG	
9		14.7000	43.91	0.00	43.91	60.00	-16.09	QP	
10		14.7000	28.69	0.00	28.69	50.00	-21.31	AVG	
11		24.2000	45.21	0.00	45.21	60.00	-14.79	QP	
12		24.2000	29.86	0.00	29.86	50.00	-20.14	AVG	

*:Maximum data x:Over limit !:over margin Comment: Factor build in receiver. Operator:KK

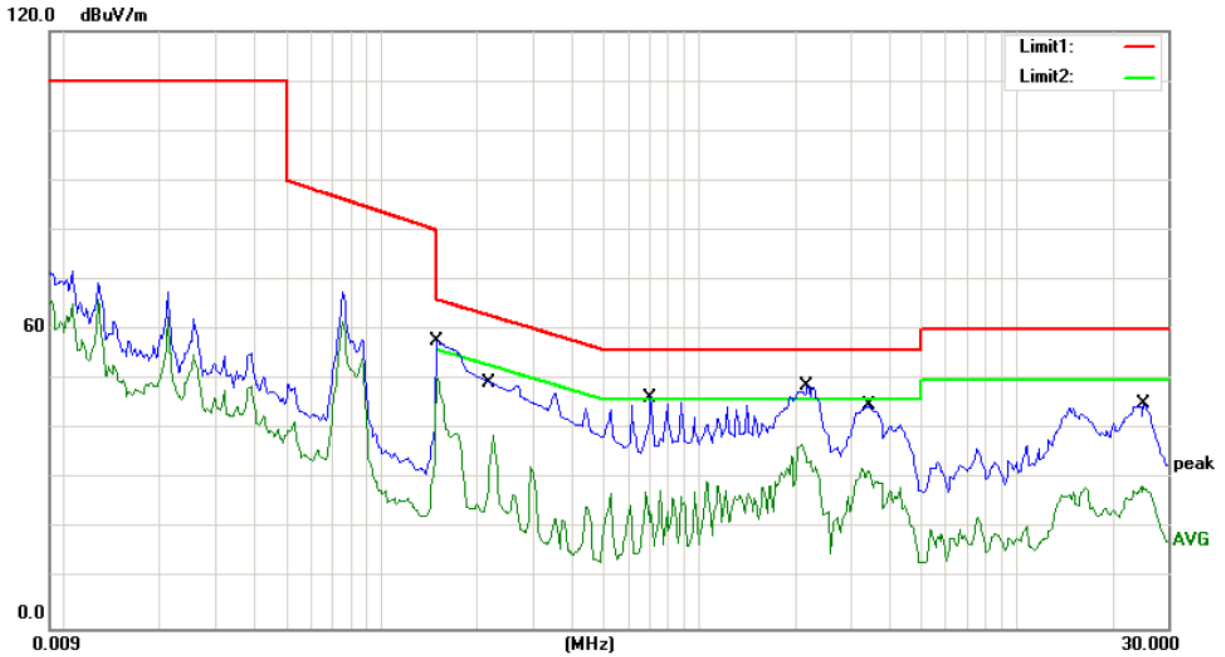

Site Conduction #2

Phase: **N**

Temperature: 26

Limit: (CE)EN55015_QP

Power: AC 230V/50Hz

Humidity: 60 %

Mode: ON

Note:

No.	Mk.	Freq.	Reading Level	Correct Factor	Measurement	Limit	Over	Detector	Comment
		MHz	dBuV/m	dB	dBuV/m	dBuV/m	dB		
1		0.1500	57.78	0.00	57.78	66.00	-8.22	QP	
2	*	0.1500	50.35	0.00	50.35	56.00	-5.65	AVG	
3		0.2250	49.54	0.00	49.54	62.63	-13.09	QP	
4		0.2250	38.73	0.00	38.73	52.63	-13.90	AVG	
5		0.7050	46.26	0.00	46.26	56.00	-9.74	QP	
6		0.7050	27.37	0.00	27.37	46.00	-18.63	AVG	
7		2.2000	48.77	0.00	48.77	56.00	-7.23	QP	
8		2.2000	36.96	0.00	36.96	46.00	-9.04	AVG	
9		3.4400	44.73	0.00	44.73	56.00	-11.27	QP	
10		3.4400	32.20	0.00	32.20	46.00	-13.80	AVG	
11		25.1500	45.06	0.00	45.06	60.00	-14.94	QP	
12		25.1500	28.58	0.00	28.58	50.00	-21.42	AVG	

*:Maximum data x:Over limit !:over margin Comment: Factor build in receiver. Operator:KK

4. MAGNETIC FIELD EMISSION MEASUREMENT

4.1. Block Diagram of Test Setup

4.1.1. Block Diagram of EUT System

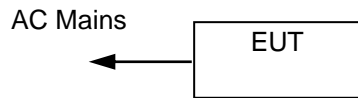

(EUT: Switchable Smart Film)

4.1.2. Block Diagram of Test Setup

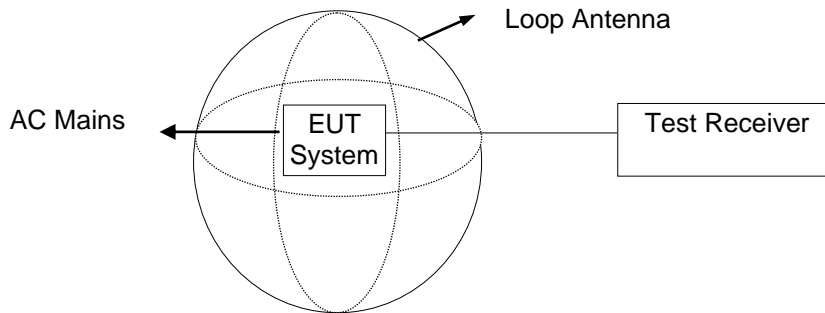

(EUT: Switchable Smart Film)

4.2. Measuring Standard and Limits

4.2.1. Test Standard

EN 55015

4.2.2. Test Limits

Frequency	Limits for loop diameter (dB μ A)	
	2m	
9kHz ~ 70kHz	88	
70kHz ~ 150kHz	88 ~ 58*	
150kHz ~ 2.2MHz	58 ~ 26*	
2.2MHz ~ 3.0MHz	58	
3.0MHz ~ 30MHz	22	

1. At the transition frequency the lower limit applies.
2. * Decreasing linearly with logarithm of the frequency.

4.3. Operating Condition of EUT

4.3.1. Setup the EUT as shown on Section 5.1.

4.3.2. Turn on the power of all equipments.

4.3.3. Let the EUT work in measuring mode (ON) and measure it.

4.4. Test Procedure

The EUT is placed on a wood table in the center of a loop antenna. The induced current in the loop antenna is measured by means of a current probe and the test receiver.

Three field components are checked by means of a coaxial switch.

The frequency range from 9kHz to 30MHz is investigated. The receiver is measured with the quasi-peak detector. For frequency band 9kHz to 150kHz, the bandwidth of the field strength meter (R&S test receiver ESCS30) is set at 200Hz. For frequency band 150kHz to 30MHz, the bandwidth is set at 9kHz.

All the test results are listed in Section 5.5, and all the scanning waveform is put in the following pages.

4.5. Measuring Results

PASS.

The frequency range from 9kHz to 30MHz is investigated.

Please refer to the following pages.



Site Conduction #1

Phase: **LOOP A**

Temperature: 26

Limit: (CE)EN55015_Radiated electromagnetic

Power: AC 230V/50Hz

Humidity: 60 %

Mode: ON

Note:

No.	Mk.	Freq.	Reading Level	Correct Factor	Measurement	Limit	Over	Detector	Comment
		MHz	dBuA	dB	dBuA	dBuA	dB		
1		0.2691	19.06	0.00	19.06	50.98	-31.92	QP	
2		2.2560	11.65	0.00	11.65	25.43	-13.78	QP	
3		8.2600	6.57	0.00	6.57	22.00	-15.43	QP	
4		12.1920	10.71	0.00	10.71	22.00	-11.29	QP	
5	*	15.1775	11.15	0.00	11.15	22.00	-10.85	QP	
6		20.3246	10.22	0.00	10.22	22.00	-11.78	QP	

*:Maximum data x:Over limit !:over margin Comment: Factor build in receiver. Operator: wq

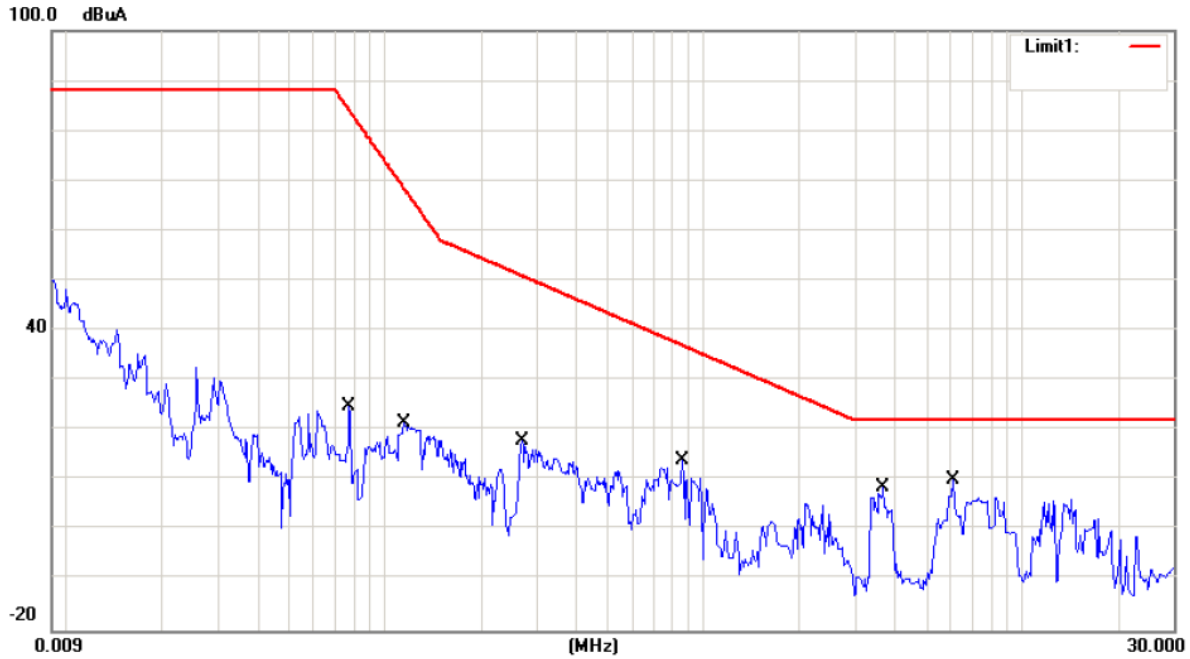

Site Conduction #1

Phase: **LOOP B**

Temperature: 26

Limit: (CE)EN55015_Radiated electromagnetic

Power: AC 230V/50Hz

Humidity: 60 %

Mode: ON

Note:

No.	Mk.	Freq.	Reading Level	Correct Factor	Measurement	Limit	Over	Detector	Comment
		MHz	dBuA	dB	dBuA	dBuA	dB		
1		0.0772	24.91	0.00	24.91	84.15	-59.24	QP	
2		0.1150	21.41	0.00	21.41	68.46	-47.05	QP	
3		0.2691	18.06	0.00	18.06	50.98	-32.92	QP	
4		0.8590	13.98	0.00	13.98	37.03	-23.05	QP	
5		3.6703	8.74	0.00	8.74	22.00	-13.26	QP	
6	*	6.0690	10.08	0.00	10.08	22.00	-11.92	QP	

*:Maximum data x:Over limit !:over margin Comment: Factor build in receiver. Operator: wq

100.0 dBuA

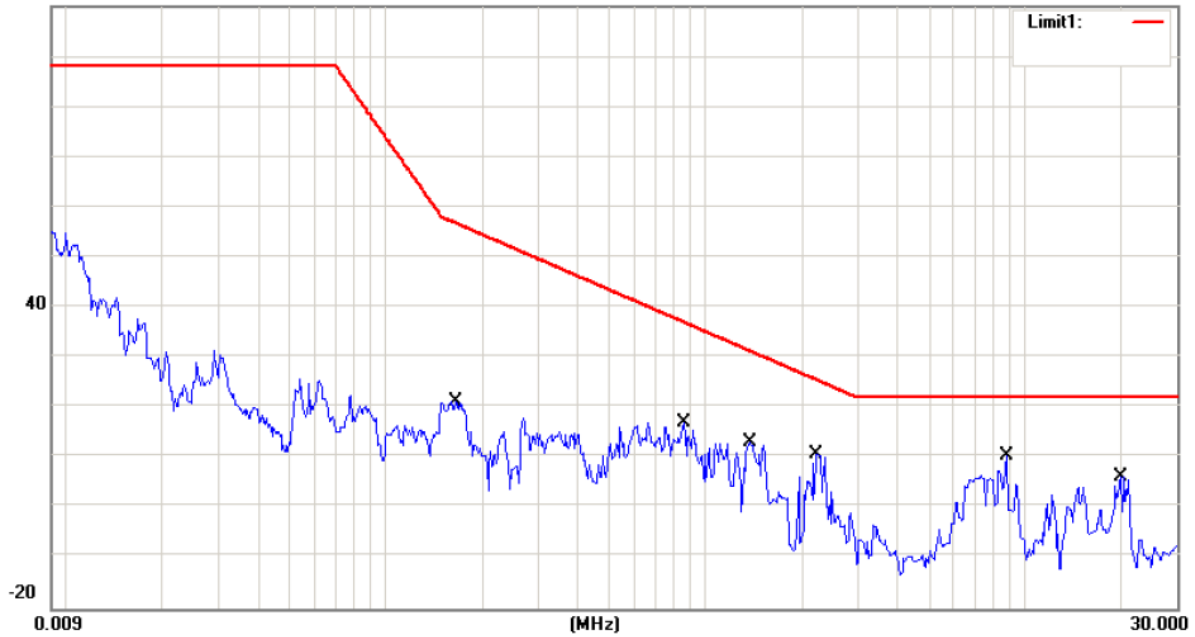

Site Conduction #1

Phase: **LOOP C**

Temperature: 26

Limit: (CE)EN55015_Radiated electromagnetic

Power: AC 230V/50Hz

Humidity: 60 %

Mode: ON

Note:

No.	Mk.	Freq.	Reading Level	Correct Factor	Measurement	Limit	Over	Detector	Comment
		MHz	dBuA	dB	dBuA	dBuA	dB		
1		0.1655	21.21	0.00	21.21	56.82	-35.61	QP	
2		0.8590	16.98	0.00	16.98	37.03	-20.05	QP	
3		1.3750	13.28	0.00	13.28	31.38	-18.10	QP	
4		2.2195	10.86	0.00	10.86	25.62	-14.76	QP	
5	*	8.8140	10.58	0.00	10.58	22.00	-11.42	QP	
6		19.9970	6.29	0.00	6.29	22.00	-15.71	QP	

*:Maximum data x:Over limit !:over margin Comment: Factor build in receiver. Operator: wq

5. RADIATED EMISSION MEASUREMENT

5.1. Block Diagram of Test Setup

5.1.1. Block diagram of EUT System

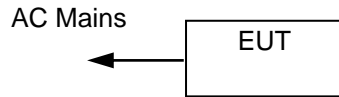

(EUT: Switchable Smart Film)

5.1.2. Block diagram of test setup (In chamber)

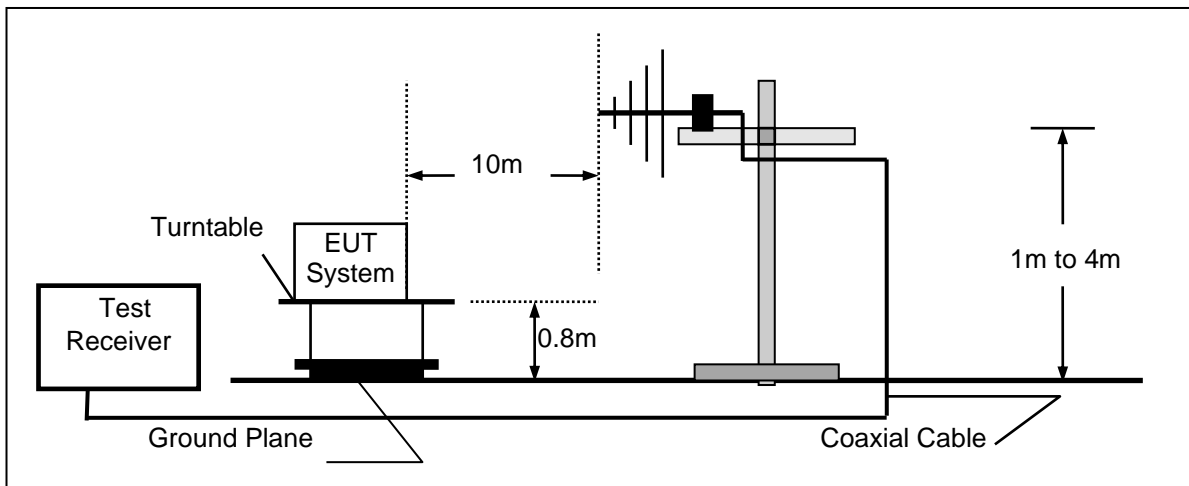

(EUT: Switchable Smart Film)

5.2. Measuring Standard and Limits

5.2.1. Test Standard

EN 55015

5.2.2. Test Limits

All emanations from a device or system, including any network of conductors and apparatus connected thereto, shall not exceed the level of field strengths specified below:

FREQUENCY (MHz)	DISTANCE (Meters)	FIELD STRENGTHS LIMIT (dB μ V/m)
30 ~ 230	10	30
230 ~ 300	10	37

- Note: (1) The smaller limit shall apply at the combination point between two frequency bands.
 (2) Distance refers to the distance in meters between the measuring instrument antenna and the closed point of any part of the EUT.

5.3. Operating Condition of EUT

- 5.3.1. Setup the EUT as shown on Section 6.1.
- 5.3.2. Turn on the power of all equipments.
- 5.3.3. Let the EUT work in measuring mode (ON) and measure it.

5.4. Test Procedure

The EUT is placed on a turntable which is 0.8 meter high above the ground. The turntable can rotate 360 degrees to determine the position of the maximum emission level. The EUT is set 3 meters away from the receiving antenna that is mounted on a antenna tower. The antenna can be moved up and down from 1 to 4 meters to find out the maximum emission level. Bilog antenna (calibrated by Dipole Antenna) is used as a receiving antenna. Both horizontal and vertical polarization of the antenna is set on test.

The bandwidth of the Receiver (ESU26) is set at 120kHz.
All the scanning curves are attached in the following pages.

5.5. Measuring Results

PASS.

The frequency range from 30MHz to 300MHz is investigated.

Please refer to the following pages.

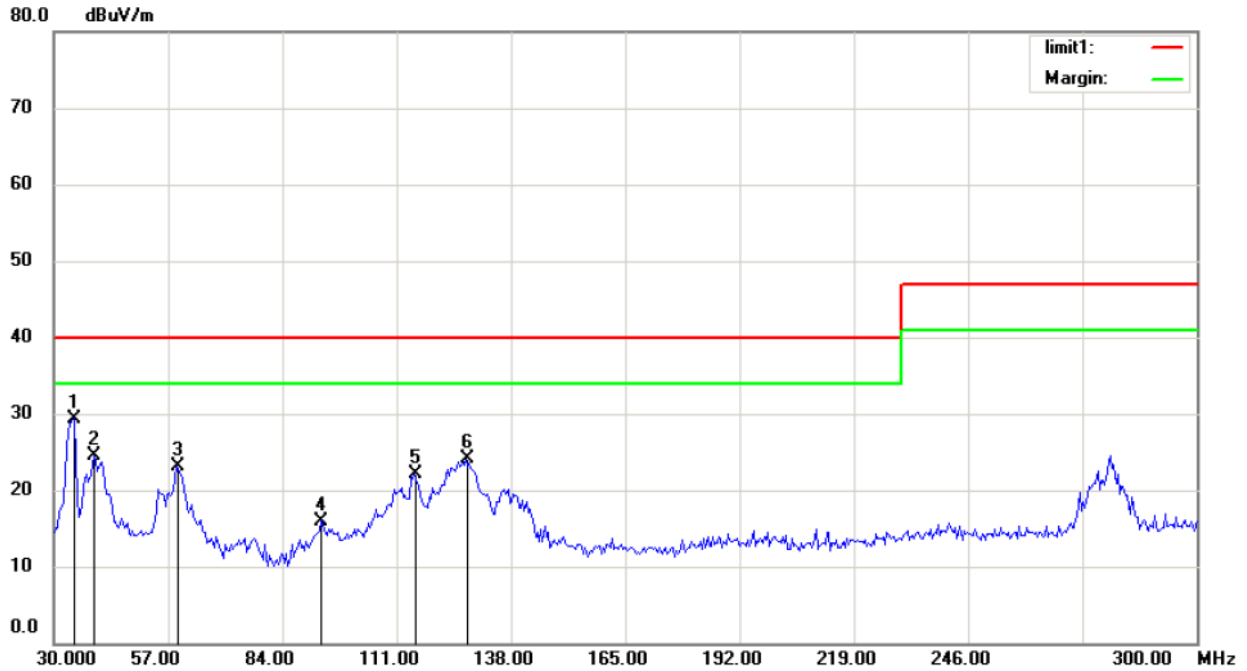

Site site #1 Polarization: **Horizontal** Temperature: 26
 Limit: (RE)EN55015 Power: AC 230V/50Hz Humidity: 60 %
 Mode:ON
 Note:

No.	Mk.	Freq.	Reading Level	Correct Factor	Measurement	Limit	Over	Antenna Height	Table Degree	
		MHz	dBuV	dB	dBuV/m	dBuV/m	dB	cm	degree	Comment
1	*	34.3270	16.51	12.83	29.34	40.00	-10.66	QP		
2		39.5191	10.46	13.97	24.43	40.00	-15.57	QP		
3		58.9904	9.67	13.38	23.05	40.00	-16.95	QP		
4		93.1730	2.84	13.16	16.00	40.00	-24.00	QP		
5		115.2404	9.46	12.55	22.01	40.00	-17.99	QP		
6		127.3558	13.09	11.05	24.14	40.00	-15.86	QP		

*:Maximum data x:Over limit !:over margin

Operator: KK

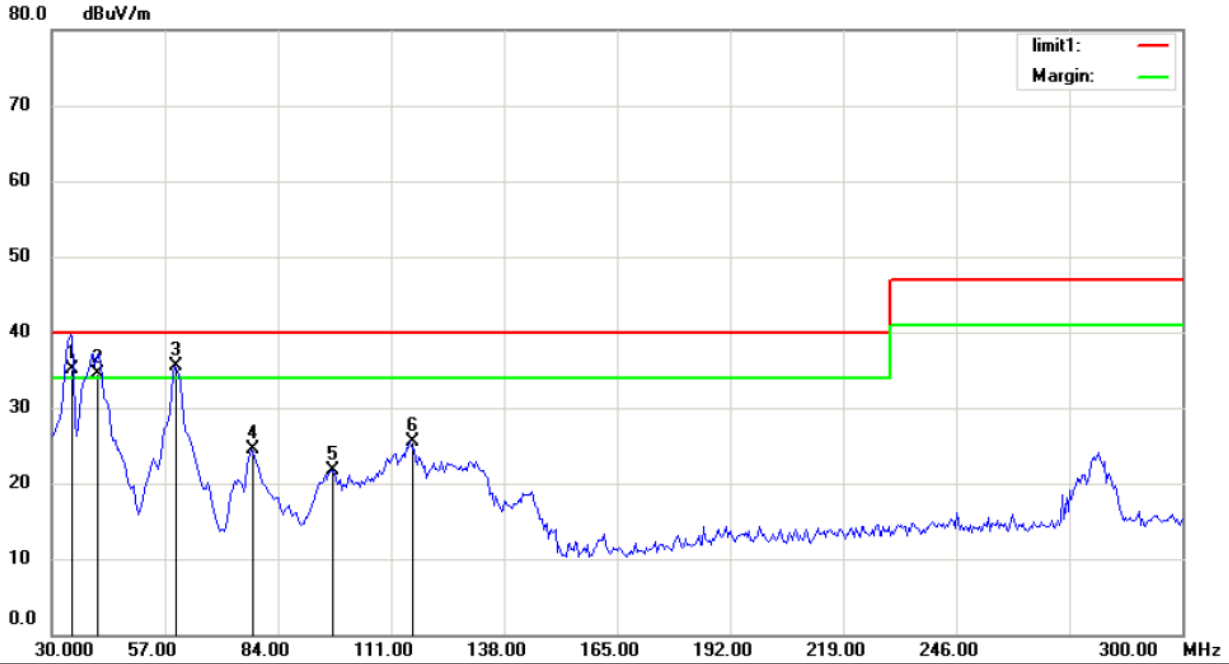

Site site #1 Polarization: **Vertical** Temperature: 26
 Limit: (RE)EN55015 Power: AC 230V/50Hz Humidity: 60 %
 Mode:ON
 Note:

No.	Mk.	Freq.	Reading Level	Correct Factor	Measurement	Limit	Over	Antenna Height	Table Degree	
		MHz	dBuV	dB	dBuV/m	dBuV/m	dB	cm	degree	Comment
1	!	34.3270	22.30	12.82	35.12	40.00	-4.88	QP		
2	!	40.8173	20.50	14.10	34.60	40.00	-5.40	QP		
3	*	59.4231	22.10	13.31	35.41	40.00	-4.59	QP		
4		77.5962	15.65	8.81	24.46	40.00	-15.54	QP		
5		97.0673	8.01	13.65	21.66	40.00	-18.34	QP		
6		115.6731	12.91	12.52	25.43	40.00	-14.57	QP		

!:Maximum data x:Over limit !:over margin

Operator: KK

6. HARMONIC CURRENT EMISSION MEASUREMENT

6.1. Block Diagram of Test Setup

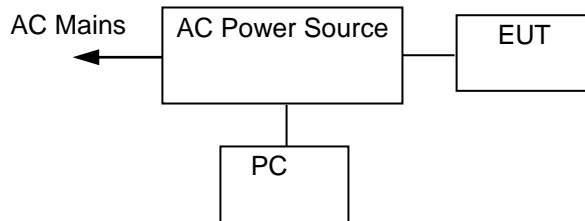

(EUT: Switchable Smart Film)

6.2. Measuring Standard

EN IEC 61000-3-2:2019 CLASS C

6.3. Operation Condition of EUT

- 6.3.1. Setup the EUT as shown on Section 7.1.
- 6.3.2. Turn on the power of all equipments.
- 6.3.3. Let the EUT work in measuring mode (ON) and measure it.

6.4. Measuring Results

Not Applicable.

7. VOLTAGE FLUCTUATION AND FLICKER MEASUREMENT

7.1. Block Diagram of Test Setup

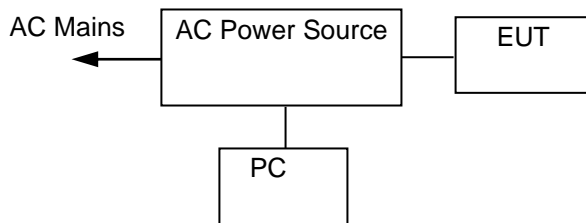

(EUT: Switchable Smart Film)

7.2. Measuring Standard

EN 61000-3-3:2013+A1:2019

7.3. Operation Condition of EUT

- 7.3.1. Setup the EUT as shown on Section 8.1.
- 7.3.2. Turn on the power of all equipments.
- 7.3.3. Let the EUT work in measuring mode (ON) and measure it.

7.4. Measuring Results

PASS.

Please refer to the following page.

Flicker Test Summary per EN/IEC61000-3-3 (Run time)

EUT: Switchable Smart Film
 Test category: All parameters (European limits)
 Test date: 2021-06-11 Start time: 15:42:40
 Test duration (min): 10 Data file name:
 Comment: ON
 Customer:

Tested by:
 Test Margin: 100
 End time:

Test Result: Pass

Status: Test Completed

Pst_t and limit line

European Limits

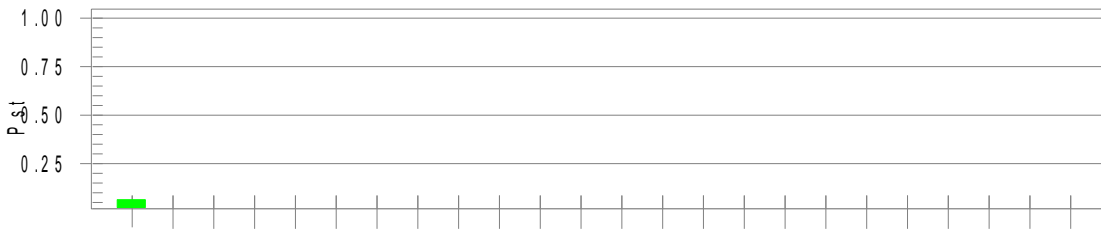

Plt and limit line

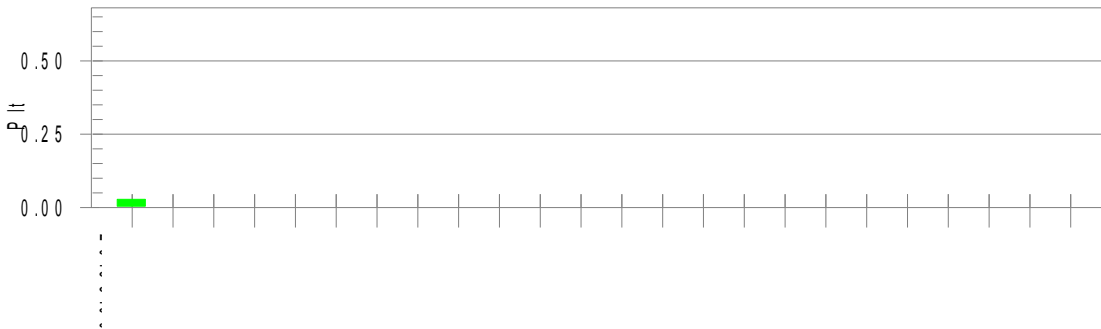

Parameter values recorded during the test:

Vrms at the end of test (Volt):	229.85		
Highest dt (%):	0.00	Test limit (%):	3.30 Pass
Time(mS) > dt:	0.0	Test limit (mS):	500.0 Pass
Highest dc (%):	0.00	Test limit (%):	3.30 Pass
Highest dmax (%):	0.00	Test limit (%):	4.00 Pass
Highest Pst (10 min. period):	0.064	Test limit:	1.000 Pass
Highest Plt (2 hr. period):	0.028	Test limit:	0.650 Pass

8. ELECTROSTATIC DISCHARGE IMMUNITY TEST

8.1. Block Diagram of Test Setup

8.1.1. Block diagram of EUT System

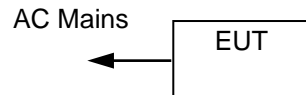

(EUT: Switchable Smart Film)

8.1.2. Block diagram of ESD test setup

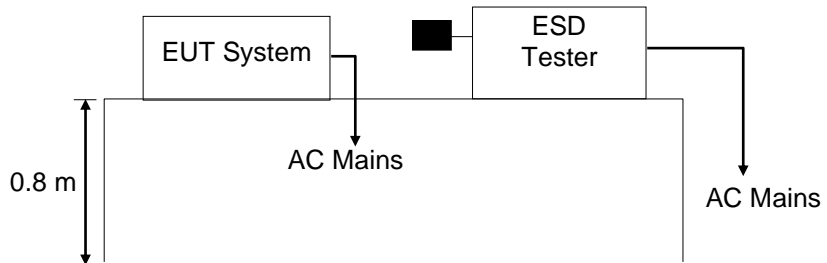

(EUT: Switchable Smart Film)

8.2. Test Standard

EN 61547:2009

8.3. Severity Levels and Performance Criterion

8.3.1. Severity level

Level	Test Voltage Contact Discharge (kV)	Test Voltage Air Discharge (kV)
1	±2	±2
2	±4	±4
3	±6	±8
4	±8	±15
X	Special	Special

8.3.2. Performance criterion: B

8.4. Operating Condition of EUT

- 8.4.1. Setup the EUT as shown on Section 9.1.
- 8.4.2. Turn on the power of all equipments.
- 8.4.3. Let the EUT work in test mode (ON) and test it.

8.5. Test Procedure

8.5.1. Air Discharge:

This test is done on a non-conductive surface. The round discharge tip of the discharge electrode shall be approached as fast as possible to touch the EUT. After each discharge, the discharge electrode shall be removed from the EUT. The generator is then re-triggered for a new single discharge and repeated 10 times for each pre-selected test point. This procedure shall be repeated until all the air discharge completed.

8.5.2. Contact Discharge:

All the procedure shall be same as Section 9.5.1. Except that the tip of the discharge electrode shall touch the EUT before the discharge switch is operated.

8.5.3. Indirect discharge for horizontal coupling plane

At least 10 single discharges (in the most sensitive polarity) shall be applied at the front edge of each HCP opposite the center point of each unit (if applicable) of the EUT and 0.1m from the front of the EUT. The long axis of the discharge electrode shall be in the plane of the HCP and perpendicular to its front edge during the discharge.

8.5.4. Indirect discharge for vertical coupling plane

At least 10 singles discharge (in the most sensitive polarity) shall be applied to the center of one vertical edge of the coupling plane. The coupling plane, of dimensions 0.5m X 0.5m, is placed parallel to, and positioned at a distance of 0.1m from the EUT. Discharges shall be applied to the coupling plane, with this plane in sufficient different positions that the four faces of the EUT are completely illuminated.

8.6. Test Results

PASS.

Please refer to the following page.

Electrostatic Discharge Test Results

Applicant	: GUANGZHOU HUICHI INDUSTRIAL DEVELOPMENT CO.,LTD	
EUT	: Switchable Smart Film	Test Date : 2021-06-11
M/N	: CT2	Temperature : 22°C
Power Supply	: AC 230V/50Hz	Humidity : 50%
Air discharge	: ± 8.0kV	Test Mode : ON
Contact discharge:	± 4.0kV	Criterion : B
Location	Kind A-Air Discharge C-Contact Discharge	Result
Slot	A	PASS
Metal	C	PASS
HCP	C	PASS
VCP of front	C	PASS
VCP of rear	C	PASS
VCP of left	C	PASS
VCP of right	C	PASS
Note:		

9. RF FIELD STRENGTH SUSCEPTIBILITY TEST

9.1. Block Diagram of Test Setup

9.1.1. Block diagram of EUT System

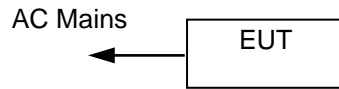

(EUT: Switchable Smart Film)

9.1.2. Block diagram of RS test setup

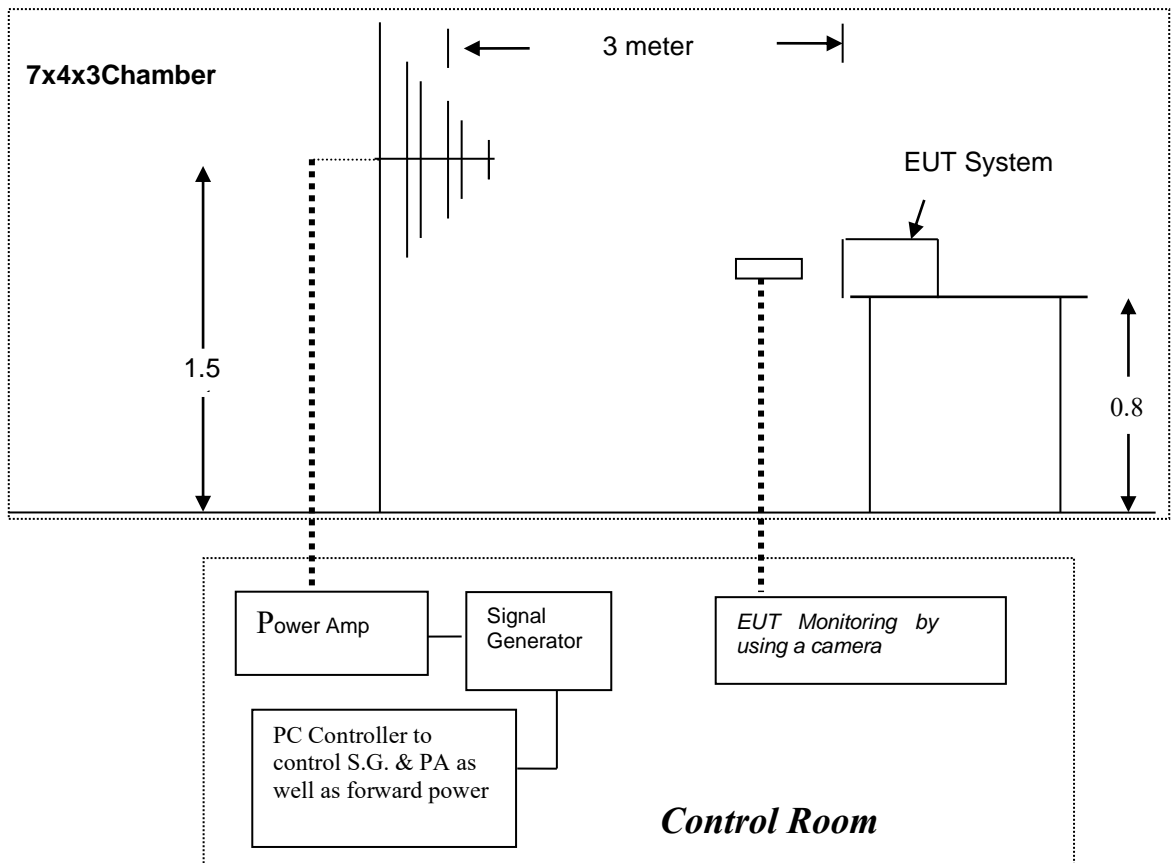

(EUT: Switchable Smart Film)

9.2. Test Standard

EN 61547:2009

9.3. Severity Levels and Performance Criterion

9.3.1. Severity Levels

Level	Field Strength V/m
1.	1
2.	3
3.	10
X.	Special

9.3.2. Performance Criterion: A

9.4. Operating Condition of EUT

9.4.1. Setup the EUT as shown on Section 10.1.

9.4.2. Turn on the power of all equipments.

9.4.3. Let the EUT work in test mode (ON) and test it.

9.5. Test Procedure

The EUT are placed on a table that is 0.8 meter high above the ground. The EUT is set 3 meters away from the transmitting antenna that is mounted on an antenna tower. Both horizontal and vertical polarization of the antenna is set on test. Each of the four sides of the EUT must be faced this transmitting antenna and measured individually.

In order to judge the EUT performance, a multimeter is used to monitor its output.

All the scanning conditions are as following:

Condition of Test	Remark
1. Fielded Strength	3V/m (Severity Level 2)
2. Radiated Signal	Modulated
3. Scanning Frequency	80-1000MHz
4. Sweep time of radiated	0.0015 Decade/s
2. Dwell Time	1 Sec.

9.6. Test Results

PASS.

Please refer to the following page.

RF Field Strength Susceptibility Test Results

Applicant	: GUANGZHOU HUICHI INDUSTRIAL DEVELOPMENT CO.,LTD			
EUT	: Switchable Smart Film	Test Date	: 2021-06-11	
M/N	: CT2	Temperature	: 22°C	
Field Strength	: 3 V/m	Humidity	: 50 %	
Power Supply	: AC 230V/50Hz	Criterion	: A	
Test Mode	: ON	Frequency Range	: 80 MHz to 1000 MHz	
Modulation: <input type="checkbox"/> None <input type="checkbox"/> Pulse <input checked="" type="checkbox"/> AM 1kHz 80%				
Frequency Rang 1: 80~ 1000MHz		Frequency Rang 2: N/A		
Steps	1%			
	Horizontal	Vertical	Horizontal	Vertical
Front	PASS	PASS		
Right	PASS	PASS		
Rear	PASS	PASS		
Left	PASS	PASS		
Test Equipment: 1. Signal Generator: 2023B (AEROFLEX) 2. Power Amplifier: AS0102-55 (MILMEGA) & AP32MT215 (PRANA) 3. Log.-Per.Antenna: VULP9118E (SCHWARZBECK) 4. Broad-Band Horn Antenna: BBHA 9120L3F (SCHWARZBECK) 5. RF Power Meter. Dual Channel: 4232A (BOONTON) 6. Field Strength Meter: HI-6005 (HOLADAY)				
Note:				

10. ELECTRICAL FAST TRANSIENT/BURST IMMUNITY TEST

10.1. Block Diagram of Test Setup

10.1.1. Block Diagram of EUT System

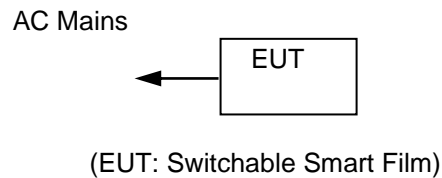

10.1.2. EFT Test Setup

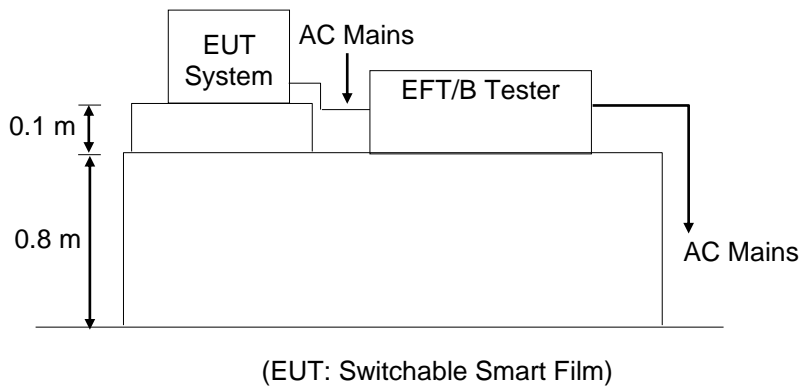

10.2. Test Standard

EN 61547:2009

10.3. Severity Levels and Performance Criterion

10.3.1. Severity level

Level	Open Circuit Output Test Voltage $\pm 10\%$	
	On Power Supply Lines	On I/O (Input/Output) Signal data and control lines
1	0.5 kV	0.25 kV
2	1 kV	0.5 kV
3	2 kV	1 kV
4	4 kV	2 kV
X	Special	Special

10.3.2. Performance criterion: B

10.4. Operating Condition of EUT

- 10.4.1. Setup the EUT as shown on Section 11.1.
- 10.4.2. Turn on the power of all equipments.
- 10.4.3. Let the EUT work in test mode (ON) and test it.

10.5. Test Procedure

The EUT is put on the table that is 0.8 meter high above the ground. This reference ground plane shall project beyond the EUT by at least 0.1m on all sides and the minimum distance between EUT and all other conductive structure, except the ground plane beneath the EUT, shall be more than 0.5m.

10.5.1. For input and output AC power ports:

The EUT is connected to the power mains by using a coupling device that couples the EFT interference signal to AC power lines. Both polarities of the test voltage should be applied during compliance test and the duration of the test is 2 mins.

10.5.2. For signal lines and control lines ports:

No I/O ports. It's unnecessary to test.

10.5.3. For DC output line ports:

It's unnecessary to test.

10.6. Test Results

PASS.

Please refer to the following page.

Electrical Fast Transient/Burst Test Results

Standard: <input checked="" type="checkbox"/> IEC 61000-4-4		Result: <input checked="" type="checkbox"/> PASS / <input type="checkbox"/> FAIL	
Applicant : GUANGZHOU HUICHI INDUSTRIAL DEVELOPMENT CO.,LTD			
EUT : Switchable Smart Film			
M/N : CT2			
Input Voltage: <u>AC 230V/50Hz</u>			
Criterion : <u>B</u>			
Ambient Condition : <u>22 °C</u>		<u>50% RH</u>	
Operation Mode: ON			
Line : <input checked="" type="checkbox"/> AC Mains		Line : <input type="checkbox"/> DC Line <input type="checkbox"/> I/O Cable	
Coupling : <input checked="" type="checkbox"/> Direct		Coupling : <input type="checkbox"/> Capacitive	
Test Time : 120s			
Line	Test Voltage	Result(+)	Result(-)
L	1kV	PASS	PASS
N	1kV	PASS	PASS
PE			
L、N	1kV	PASS	PASS
L、PE			
N、PE			
L、N、PE			
Signal Line			
DC Line			
Note:			

11. SURGE IMMUNITY TEST

11.1. Block Diagram of Test Setup

11.1.1. Block Diagram of EUT System

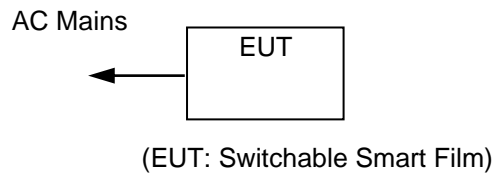

11.1.2. Surge Test Setup

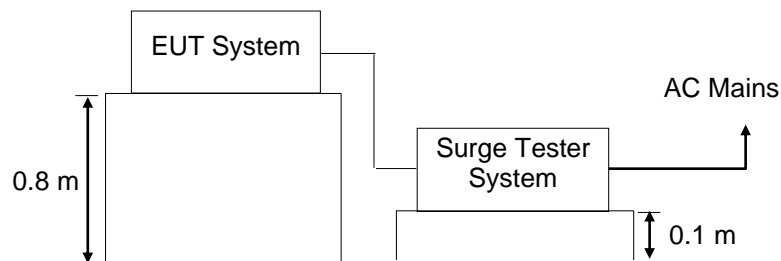

(EUT: Switchable Smart Film)

11.2. Test Standard

EN 61547:2009

(IEC 61000-4-5:2005, Severity Level: Line to Line: 0.5kV)

11.3. Severity Levels and Performance Criterion

11.3.1. Severity level

Severity Level	Open-Circuit Test Voltage kV
1	0.5
2	1.0
3	2.0
4	4.0
*	Special

11.3.2. Performance criterion: B

11.4. Operating Condition of EUT

- 11.4.1. Setup the EUT as shown on Section 12.1.
- 11.4.2. Turn on the power of all equipments.
- 11.4.3. Let the EUT work in test mode (ON) and test it.

11.5. Test Procedure

- 1) Set up the EUT and test generator as shown on Section 12.1.2.
- 2) For line to line coupling mode, provide a 0.5kV 1.2/50us voltage surge (At open-circuit condition) and 8/20us current surge to EUT selected points.
- 3) At least 5 positive and 5 negative (polarity) tests with a maximum 1/min repetition rate are conducted during test.
- 4) Different phase angles are done individually.
- 5) Record the EUT operating situation during compliance test and decide the EUT immunity criterion for above each test.

11.6. Test Results

PASS.

Please refer to the following page.

12. INJECTED CURRENTS SUSCEPTIBILITY TEST

12.1. Block Diagram of Test Setup

12.1.1. Block Diagram of EUT System

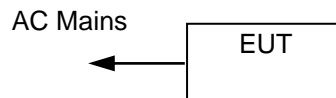

(EUT: Switchable Smart Film)

12.1.2. Block Diagram of Test Setup

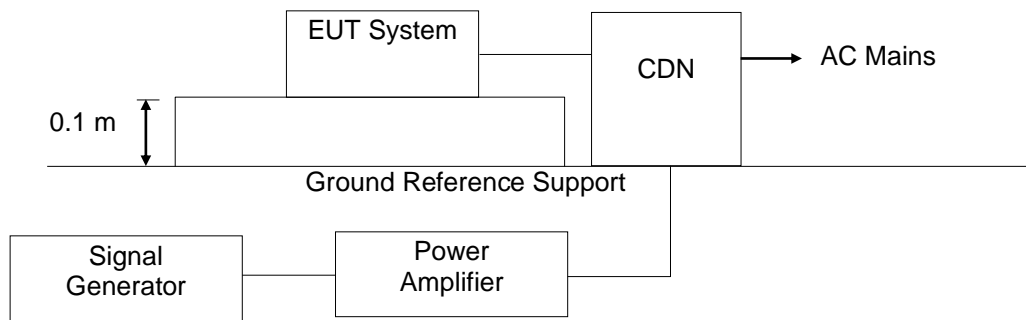

(EUT: Switchable Smart Film)

12.2. Test Standard

EN 61547:2009

12.3. Severity Levels and Performance Criterion

12.3.1. Severity level

Level	Field Strength V
1	1
2	3
3	10
X	Special

12.3.2. Performance criterion: A

12.4. Operating Condition of EUT

- 12.4.1. Setup the EUT as shown on Section 13.1.
- 12.4.2. Turn on the power of all equipments.
- 12.4.3. Let the EUT work in test mode (ON) and test it.

12.5. Test Procedure

- 1) Set up the EUT, CDN and test generators as shown on Section 13.1.2.
- 2) Let the EUT work in test mode and measure it.
- 3) The EUT are placed on an insulating support 0.1m high above a ground reference plane. CDN (coupling and decoupling device) is placed on the ground plane about 0.3m from EUT. Cables between CDN and EUT are as short as possible, and their height above the ground reference plane shall be between 30 and 50 mm (where possible).
- 4) The disturbance signal described below is injected to EUT through CDN.
- 5) The EUT operates within its operational mode(s) under intended climatic conditions after power on.
- 6) The frequency range is swept from 150kHz to 80MHz using 3V signal level, and with the disturbance signal 80% amplitude modulated with a 1kHz sine wave.
- 7) The rate of sweep shall not exceed 1.5×10^{-3} decades/s. where the frequency is swept incrementally; the step size shall not exceed 1% of the start and thereafter 1% of the preceding frequency value.
- 8) Recording the EUT operating situation during compliance testing and decide the EUT immunity criterion.

12.6. Test Results

PASS.

Please refer to the following page.

Injected Currents Susceptibility Test Results

Applicant : GUANGZHOU HUICHI INDUSTRIAL DEVELOPMENT CO.,LTD				
EUT : Switchable Smart Film		Test Date : 2021-06-11		
M/N : CT2		Temperature : 22°C		
Power Supply : AC 230V / 50Hz		Humidity : 55%		
Test Engineer : _____				
Test Mode: ON				
Frequency Range (MHz)	Injected Position	Strength (Unmodulated)	Criterion	Result
0.15 ~ 80	AC Mains	3V	A	PASS
Test Mode : N/A				
Frequency Range (MHz)	Injected Position	Strength (Unmodulated)	Criterion	Result
Remark : 1. Modulation Signal:1kHz 80% AM Measurement Equipment : Simulator: CWS 500 (SWITZERLAND EMTEST) CDN : <input checked="" type="checkbox"/> CDN-M2 (SWITZERLAND EMTEST) <input type="checkbox"/> CDN-M3 (SWITZERLAND EMTEST)		Note:		

13. MAGNETIC FIELD SUSCEPTIBILITY TEST

13.1. Block Diagram of Test Setup

13.1.1. Block Diagram of EUT System

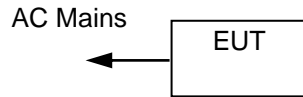

(EUT: Switchable Smart Film)

13.1.2. Magnetic field test setup

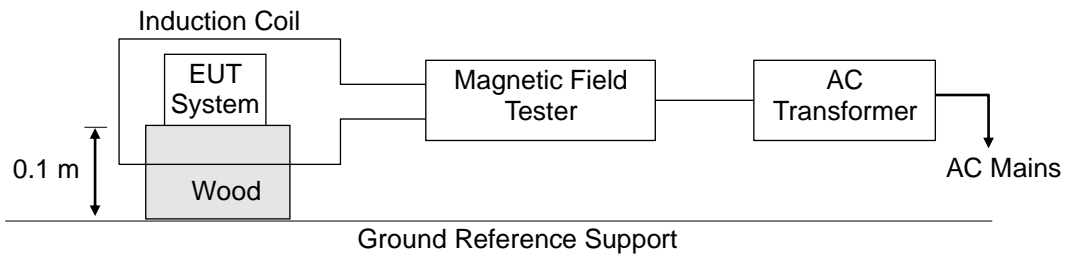

(EUT: Switchable Smart Film)

13.2. Test Standard

EN 61547:2009

13.3. Severity Levels and Performance Criterion

13.3.1. Severity Levels

Level	Field Strength A/m
1	1
2	3
3	10
4	30
5	100
X	Special

13.3.2. Performance Criterion: A

13.4. Operating Condition of EUT

- 13.4.1. Setup the EUT as shown on Section 14.1.
- 13.4.2. Turn on the power of all equipments.
- 13.4.3. Let the EUT work in test mode (ON) and test it.

13.5. Test Procedure

The EUT is placed in the middle of a induction coil (1*1m), under which is a 1*1*0.1m (high) table, this small table is also placed on a larger table, 0.8 m above the ground. Both horizontal and vertical polarization of the induction coil is set on test, so that each side of the EUT is affected by the magnetic field. Also can reach the same aim by change the position of the EUT.

13.6. Test Results

PASS.

Please refer to the following page.

Magnetic Field Immunity Test Results

Standard: <input checked="" type="checkbox"/> IEC 61000-4-8		Result: <input checked="" type="checkbox"/> PASS / <input type="checkbox"/> FAIL		
Applicant : GUANGZHOU HUICHI INDUSTRIAL DEVELOPMENT CO.,LTD EUT : Switchable Smart Film M/N : CT2 Input Voltage : AC230V/50Hz Date of Test : 2021-06-11 Test Engineer: _____ Ambient Condition : Temp : 25°C Humid: 50% Criterion: A				
Operation Mode: <u>ON</u>				
Test Level (A/m)	Testing Duration	Coil Orientation	Criterion	Result
3	5 mins	X	A	PASS
3	5 mins	Y	A	PASS
3	5 mins	Z	A	PASS
Operation Mode: N/A				
Test Level (A/m)	Testing Duration	Coil Orientation	Criterion	Result
Test Equipment	Magnetic Field Test: HEAFELY MAG 100.1			
Note:				

14. VOLTAGE DIPS AND INTERRUPTIONS TEST

14.1. Block Diagram of Test Setup

14.1.1. Block Diagram of EUT System

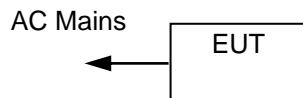

(EUT: Switchable Smart Film)

14.1.2. Dips Test Setup

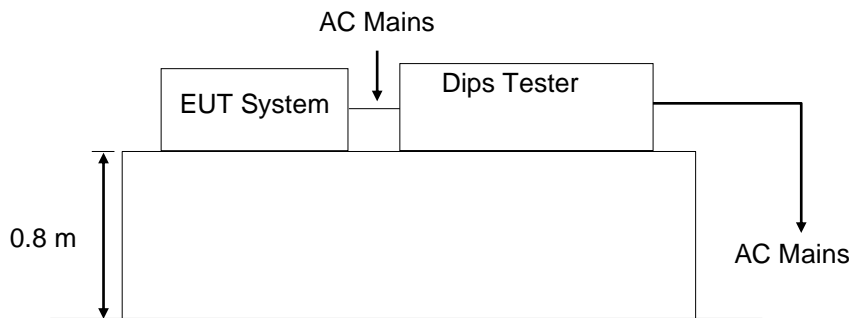

(EUT: Switchable Smart Film)

14.2. Test Standard

EN 61547:2009

14.3. Severity Levels and Performance Criterion

14.3.1. Severity level

Test Level %UT	Voltage dip and short interruptions %UT	Duration (in period)
0	100	0.5
70	30	10

14.3.2. Performance criterion: B&C

14.4. Operating Condition of EUT

14.4.1. Setup the EUT as shown on Section 15.1.

14.4.2. Turn on the power of all equipments.

14.4.3. Let the EUT work in test mode (ON) and test it.

14.5. Test Procedure

- 1) Set up the EUT and test generator as shown on Section 15.1.2.
- 2) The interruption is introduced at selected phase angles with specified duration.
- 3) Record any degradation of performance.

14.6. Test Results

PASS.

Please refer to the following page.

Voltage Dips and Interruptions Test Results

Applicant : GUANGZHOU HUICHI INDUSTRIAL DEVELOPMENT CO.,LTD				
EUT : Switchable Smart Film			Test Date : 2021-06-11	
M/N : CT2			Temperature : 25°C	
Power Supply : AC 230V/50Hz			Humidity : 50%	
Test Mode: <u>ON</u>				
Test Level % U _T	Voltage Dips & Short Interruptions % U _T	Duration (in periods)	Criterion <input type="checkbox"/> A <input checked="" type="checkbox"/> B <input checked="" type="checkbox"/> C <input type="checkbox"/> D	Result P=PASS F=FAIL
0	100	0.5P	B	PASS
70	30	10P	C	PASS
Test Mode : <u>N/A</u>				
Test Level % U _T	Voltage Dips & Short Interruptions % U _T	Duration (in periods)	Criterion <input type="checkbox"/> A <input type="checkbox"/> B <input type="checkbox"/> C <input type="checkbox"/> D	Result P=PASS F=FAIL
Note:				

Appendix 1 (Photos of EUT)

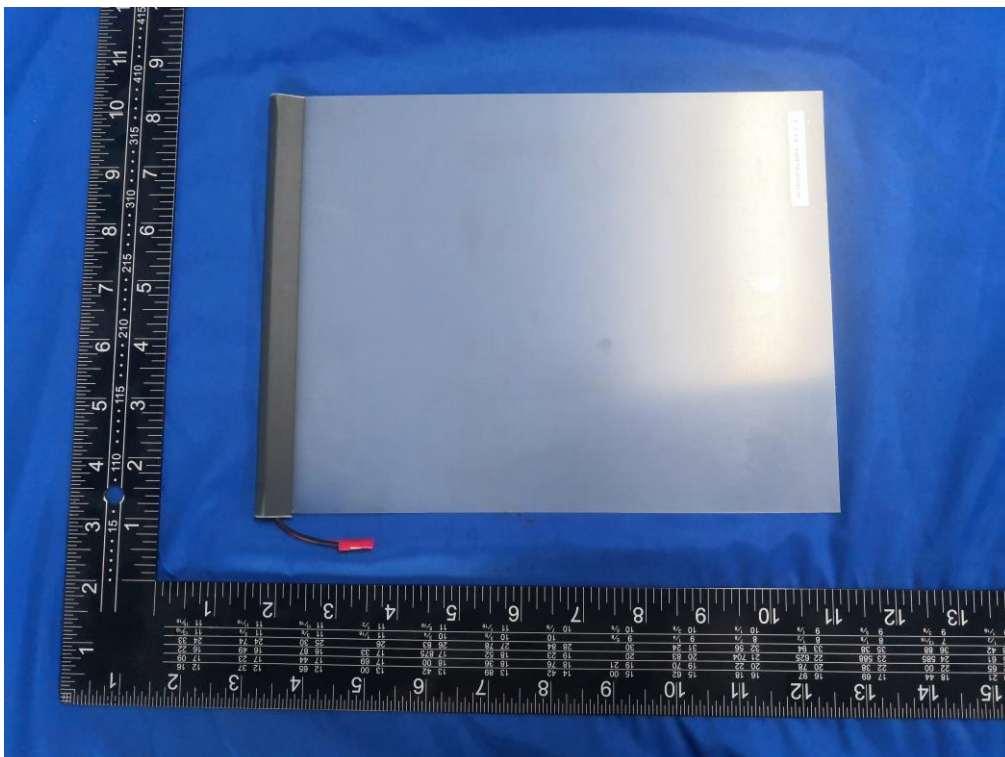

End of Report